

BV10S-2366HE-PN10/PN16/A150 - Levier

Vanne à papillon type Wafer, montage entre brides PN10/PN16/A150, à levier verrouillable

Norme d'écartement: EN 558-1 Tableau 1 série 20

Siège en "high temperature" EPDM, max. pression de service 16 bar, -20°C à 130°C



N° d'article	Réf. Belven
10S003037HE10050	BV10S-2366HE-PN16-DN050 - LEVER
10S003037HE10065	BV10S-2366HE-PN16-DN065 - LEVER
10S003037HE10080	BV10S-2366HE-PN16-DN080 - LEVER
10S003037HE10100	BV10S-2366HE-PN16-DN100 - LEVER
10S003037HE10125	BV10S-2366HE-PN16-DN125 - LEVER
10S003037HE10150	BV10S-2366HE-PN16-DN150 - LEVER
10S003037HE10200	BV10S-2366HE-PN16-DN200 - LEVER
10S003037HE10250	BV10S-2366HE-PN16-DN250 - LEVER
10S003037HE10300	BV10S-2366HE-PN16-DN300 - LEVER

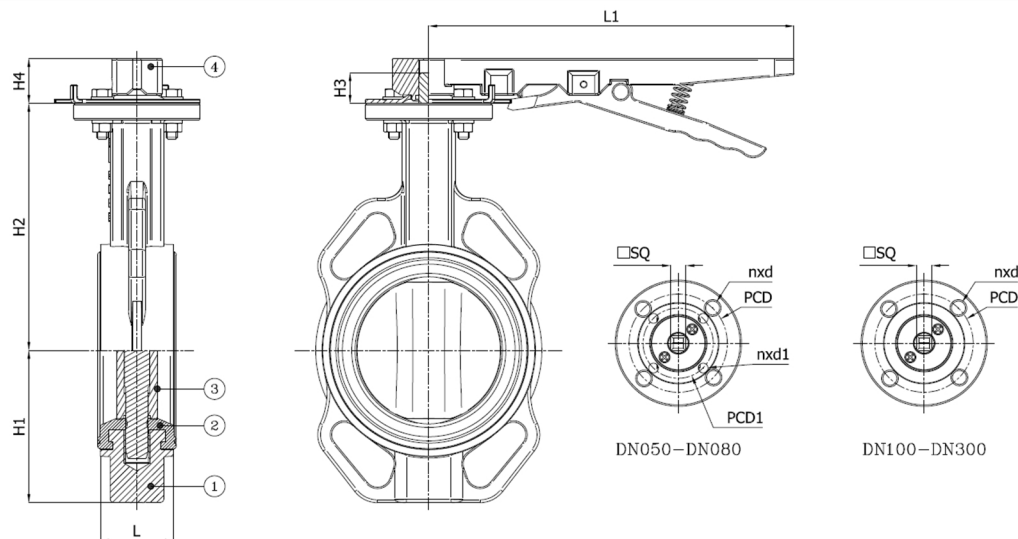

DN/Pouce	L	H1	H2	H3	H4	L1	SQ	ISO	PCD	n x d1	PCD1	ISO1	n x d	Cl. press.	Poids(kg)
DN050 (2")	43	64	140,5	22	29	260	11	F05	50	4 x d10	70	F07	4 x d7	PN16	4,00
DN065 (2 1/2")	46	71,4	152,5	22	29	260	11	F05	50	4 x d10	70	F07	4 x d7	PN16	4,70
DN080 (3")	46	94	157,5	22	29	260	11	F05	50	4 x d10	70	F07	4 x d7	PN16	5,10
DN100 (4")	52	108,5	176	22	29	260	14	F07	70	4 x d10				PN16	6,60
DN125 (5")	56	119	191	22	29	260	14	F07	70	4 x d10				PN16	8,40
DN150 (6")	56	136	202,5	22	29	260	14	F07	70	4 x d10				PN16	9,90
DN200 (8")	60	165	243,5	34,5	45	350	17	F10	102	4 x d12				PN16	18,50
DN250 (10")	68	202	273	34,5	45	350	22	F10	102	4 x d12				PN16	25,00
DN300 (12")	78	235	311	34,5	45	350	27	F12	125	4 x d14				PN16	36,00

Item 1	Item 2	Item 3	Item 4
Matériau Corps	Matériau Siège	Matériau Clapet	Matériau Commande
Fonte : GG25 + revêtement epoxy	HT-EPDM	Acier inoxydable : CF8M	Fonte malléable